

DO NOT SCALE

IF IN DOUBT ASK

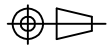

Revisions

Rev	Description	Date	Approved
-----	-------------	------	----------

### - SBU-3 SPECIFICATION -

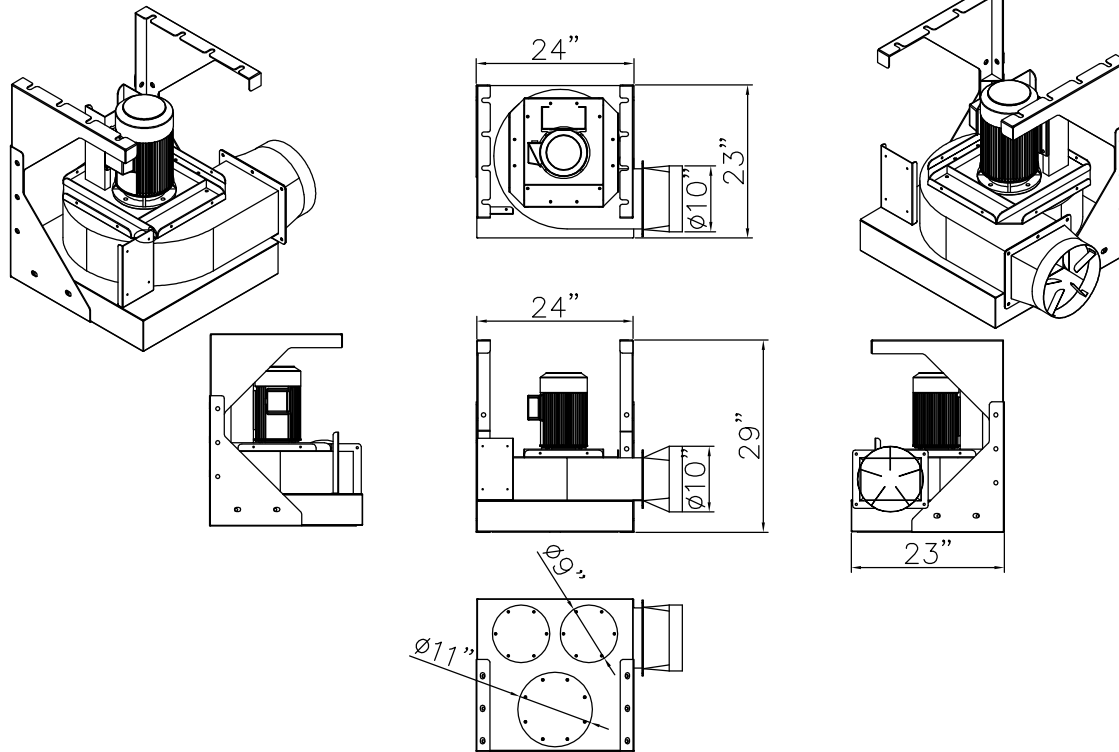

- Direct Drive Blower
- Motor: 3HP x 1 pc
- CFM: 1,917 ft<sup>3</sup>/min
- Arm Port Size: dia. 6" x 2 holes  
dia. 8" x 1 hole
- Construction: 14 Gauge Steel Cabinet
- Packing Size (L x W x H): 74 x 68 x 73 cm  
29.2" x 26.8" x 28.8"
- N.W.: 74 kgs / 163.1 lbs
- G.W.: 94 kgs / 207.2 lbs

**Include:**

- control panel
- remote control
- standard wall-mounting brackets

**OPTIONS**

\*\*\*optional ceiling-mounting brackets

AVANI ENVIRONMENTAL INTL. INC. Sales Department  
 95 Cypress Drive (919) 570-2862  
 Youngsville, NC 27596 info@avanienvironmental.com

	Date	Name	Part Number:	Title:	
Drawn by:	2010-05-25	***	DBB-3	Blower SBU-3	
Checked by:					
The drawings, AutoCAD, 3-D Models, and specifications are the property of Avani Environmental Intl. Inc. (AE) and may not be reproduced, distributed, modified, or otherwise used, except provided herein, without the express written permission of AE.			Size	Scale	Drawing Number:
			A	1 = 1	DBB-3